

IN ACCORDANCE WITH ANSI/APSP/ICC-5 2011, THE INSTALLER IS RESPONSIBLE FOR PLACING ONE SKIMMER FOR EVERY 800 SQUARE FEET OF SURFACE AREA AND ONE RETURN FOR EVERY 300 SQUARE FEET OF SURFACE AREA.

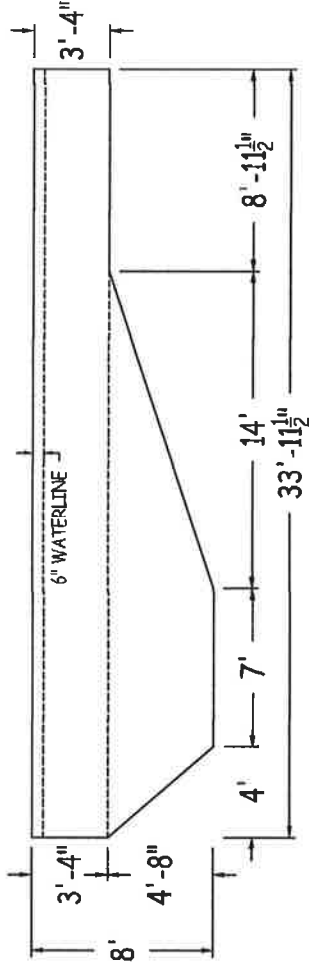
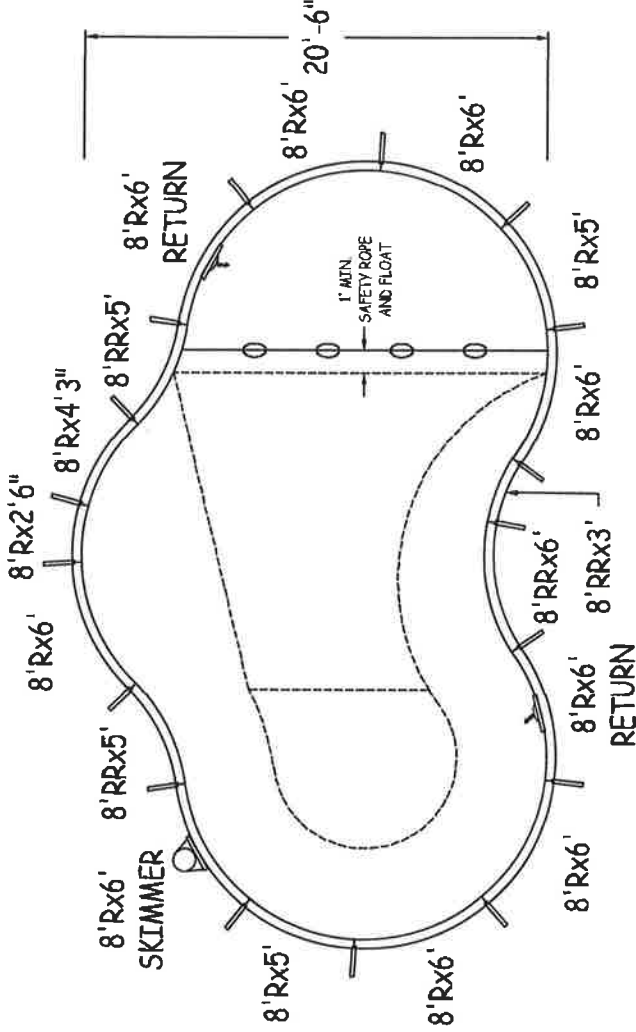
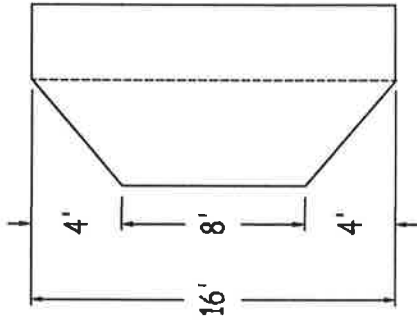

RECEIVED
MAY 10 2023
CLEARCREEK TOWNSHIP
ZONING DEPT.

LATHAM STEEL GEMINI 16-0 x 20-6 x 33-11 LEFT

42" STEEL PANELS	PERIMETER:	89'-9"	VOLUME (US Gal):	16800	
DWG#:	SURFACE (ft²):	513	VOLUME (Liters):	63600	
2019-SPL-03904	LINER (ft²):	543	DATE:	2/12/2019 DSR:	
KIT#:	CUSTOMKIT	COVER (ft²):	868	SCALE:	1/8" = 1'-0"

ALL ASPECTS OF THIS DRAWING COMPLY WITH ANSI/APSP/ICC-5 2011 AND 2015 ISFSC

ALWAYS ENTER POOL
Feet First

DIVING/SLIDING EQUIPMENT SHALL BE DESIGNED FOR SWIMMING POOLS AND SHALL BE INSTALLED IN ACCORDANCE WITH THE DIVING/SLIDING EQUIPMENT MANUFACTURER'S SPECIFICATIONS. PLEASE CONTACT THE DIVING/SLIDING EQUIPMENT MANUFACTURER FOR THEIR SPECIFICATIONS.

CUSTOMER:

JOB NAME:

Center To Center	3 to 4	25'-8 1/2"	S2 to H2	14'-0"	8 to 9	11'-5 1/4"	9 to 14	25'-9 1/2"	13 to 14	10'-10 3/4"
1 to 2	10'-1/2"	16'-0"	S1 to H2	21'-2 1/2"	8 to 10	16'-0"	10 to 11	10'-10 3/4"		
1 to 3	17'-11 1/4"	16'-0"	H1 to S2	22'-7 3/4"	8 to 11	25'-3/4"	10 to 12	15'-6 1/2"		
1 to 4	16'-0"	22'-7"	7 to 8	4'-11"	8 to 12	19'-4"	10 to 13	20'-4 1/4"		
1 to 5	25'-8 1/2"	31'-2 1/4"	7 to 9	16'-0"	8 to 13	16'-7 1/2"	10 to 14	28'-5"		
1 to 6	16'-0"	31'-2 1/4"	7 to 10	20'-3 1/4"	8 to 14	17'-10 3/4"	11 to 12	13'-11 3/4"		
2 to 3	10'-1/2"	Diagonals	7 to 11	28'-4 3/4"	9 to 10	4'-11"	11 to 13	22'-1 1/4"		
2 to 4	16'-0"	S1 to S2	7 to 12	20'-4 1/4"	9 to 11	15'-6"	11 to 14	32'-4 1/2"		
2 to 5	16'-0"	H1 to H2	7 to 13	15'-6 1/2"	9 to 12	16'-7 1/2"	12 to 13	8'-6 1/2"		
2 to 6	17'-8 3/4"	S1 to H1	7 to 14	13'-11 3/4"	9 to 13	19'-4"	12 to 14	19'-4 3/4"		

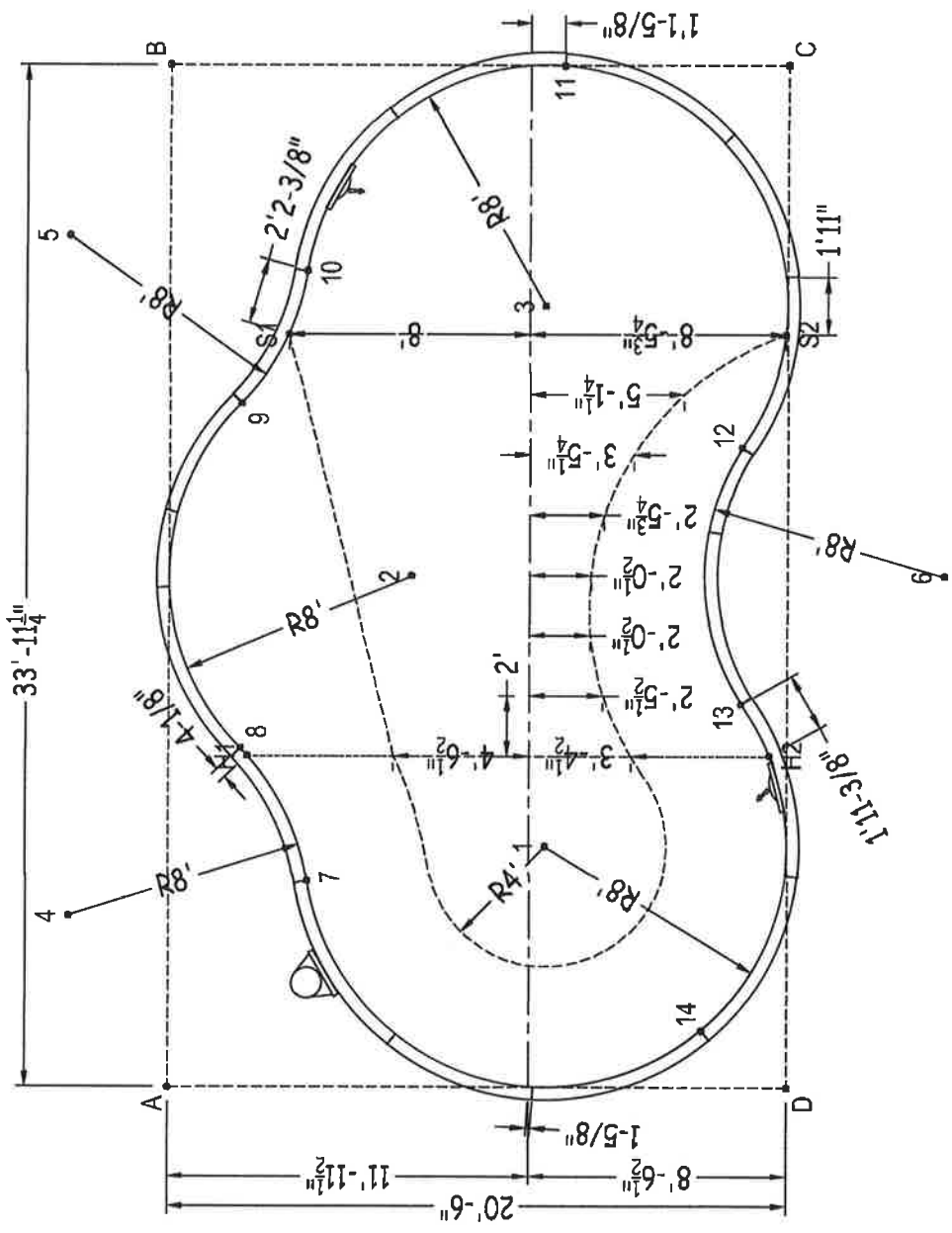

RECEIVED
MAY 10 2023
CLEARCREEK TOWNSHIP
ZONING DEPT.

Part number	Description	QTY
RA0720961X	8"Rx6"	6
RA0720961*	8"Rx6" RETURN	2
RA0720961*	8"Rx6" SKIMMER	1
RA0600961X	8"Rx5"	2
RA0510961X	8"Rx4 3/4"	1
RA0300960X	8"Rx2 6"	1
RR0720961X	8"RRx6"	1
RR0600961X	8"RRx5"	2
RR0360960X	8"RRx3"	1
Brace	Brace	17
IPC-STKPK25	REBAR STAKE 18" 25PC	2
IPC-HDWSRT150	BOLT STR 3/8-16X1" C/W NUT 150PC	2

	A	B	C	D
1	14'-10"	28'-9 1/2"	27'-1 3/4"	11'-3 3/4"
2	18'-9 1/4"	18'-9 1/4"	21'-1"	21'-1"
3	28'-9 1/2"	14'-10"	11'-3 3/4"	27'-1 3/4"
4	6'-7"	28'-5 1/2"	36'-11 3/4"	24'-6"
5	28'-5 1/2"	6'-7"	24'-6"	36'-11 3/4"
6	30'-10"	30'-10"	17'-9 1/4"	17'-9 1/4"
7	8'-2 3/4"	27'-6"	31'-5 1/4"	17'-3 3/4"
8	11'-6"	22'-9 3/4"	29'-1 1/4"	21'-3 3/4"
9	22'-9 3/4"	11'-6"	21'-3 3/4"	21'-3 3/4"
10	27'-6"	8'-2 3/4"	17'-3 3/4"	31'-5 1/4"
11	36'-4 1/4"	13'-1 1/4"	7'-4 3/4"	34'-8 3/4"
12	28'-5 3/4"	22'-10"	12'-9 1/2"	21'-3 1/2"
13	22'-10"	28'-5 3/4"	21'-3 1/2"	12'-9 1/2"
14	17'-9"	36'-7 1/4"	32'-2 1/4"	3'-5"
S2	32'-3 1/2"	22'-3 3/4"	8'-11 1/4"	25'-0"
S1	25'-3 3/4"	9'-9 1/2"	18'-9 1/2"	29'-11 3/4"
H2	22'-9"	30'-4 1/2"	22'-11 1/2"	11'-1 1/4"
H1	11'-3 3/4"	23'-1 1/4"	29'-1"	20'-11 3/4"
A	-	33'-11 1/4"	39'-7 3/4"	20'-6"

QF

23382375

2-28
By Chicago
Out

GENERAL WARRANTY DEED, Statutory Form No. 22-S (Revised 2/2002)

Registered in U.S Patent and Trademark Office
anderson publishing co. cincinnati, ohio 45202

General Warranty Deed*

STONERIDGE DEVELOPMENT, LTD., AN OHIO
LIMITED LIABILITY COMPANY

~~1st~~

~~XXXXX~~

for valuable consideration paid, grant(s) with general warranty covenants, to **RODNEY K. LITTERAL AND
MONICA L.M. LITTERAL, HUSBAND AND WIFE, FOR THEIR JOINT LIVES,** , whose tax-mailing address is
REMAINDER TO THE SURVIVOR OF THEM

407 Greensboro Dr. Centerville, OH 45459

the following **REAL PROPERTY**: Situated in the County of **WARREN** in the State
of Ohio and in the **TOWNSHIP** of **CLEARCREEK** ;²

SITUATED IN SECTION 31, TOWN 3, RANGE 5 IN THE TOWNSHIP OF CLEARCREEK, COUNTY OF WARREN,
STATE OF OHIO AND BEING LOT NUMBERED 43 ON THE REPLAT OF LOTS 21, 22 AND 23 COUNTRY BROOK,
SECTION ONE AS RECORDED IN PLAT BOOK 63, PAGE 63 OF THE PLAT RECORDS OF WARREN COUNTY,
OHIO.

OUT OF ACCOUNT NO. 0119156, SIDWELL NO. 05-31-205-~~027~~ ⁰⁴³ *W*

SUBJECT TO TAXES AND ASSESSMENTS WHICH ARE NOW OR MAY HEREAFTER BECOME LIENS ON SAID
PREMISES AND EXCEPT CONDITIONS AND RESTRICTIONS AND EASEMENTS, IF ANY, CONTAINED IN
FORMER DEEDS OF RECORD FOR SAID PREMISES, SUBJECT TO ALL OF WHICH THIS CONVEYANCE IS
MADE.

Prior Instrument Reference: Volume 2569 Page 16 of the Deed Records of WARREN
County, Ohio.

~~WHEREAS THE RIGHTS OF THE GRANTOR~~

~~IN THE DEED RECORDS OF THE COUNTY~~

EXECUTED this 13TH day of **NOVEMBER** , 2003 (Year).⁴

STONERIDGE DEVELOPMENT, LTD., AN OHIO
LIMITED LIABILITY COMPANY

Robert D. Abernathy
BY **ROBERT D. ABERNATHY**
ITS AGENT

STATE OF OHIO)
COUNTY OF **MONTGOMERY**) SS:

BE IT REMEMBERED, That on this 13TH day of **NOVEMBER** , 2003 (Year) before me,
the subscriber, a **NOTARY PUBLIC** In and for said state, personally came,
STONERIDGE DEVELOPMENT, LTD., AN OHIO LIMITED LIABILITY COMPANY the Grantor(s) in the
BY **ROBERT D. ABERNATHY, ITS AGENT**
foregoing deed, and acknowledged the signing thereof to be **ITS/HIS** voluntary act and deed.

IN TESTIMONY THEREOF I have hereunto subscribed my name and affixed my **OFFICIAL** seal
on the day and year last aforesaid



PAMELA SUE MOORE
Notary Public
In and for the State of Ohio
My Commission Expires
June 18, 2008

Pamela Sue Moore

This instrument was prepared by **WILLIAM H. FRAPWELL, ATTORNEY AT LAW**

- 1 Name of Grantor(s) and marital status.
- 2 Description of land or interest therein, and encumbrances, reservations, and exceptions, taxes and assessments, if any.
- 3 Delete whichever does not apply.
- 4 Execution in accordance with Chapter 5301 Ohio Revised Code.

Auditor's and Recorder's Stamps

BOOK 3377 PAGE 720

*See Sections 5302.05 and 5302.06 Ohio Revised Code.

General Warranty Deed

CHICAGO TITLE INSURANCE CO.
ONE DAYTON CENTRE
ONE S. MAIN ST., STE 330
DAYTON, OHIO 45402
ATTN: JOYCE KRAMER

FROM

WPS
TRANSFERRED

DEC 11 2003

12/10
OK
SEC. 319.202 COMPLIED WITH
NICK NELSON, Auditor
WARREN COUNTY, OHIO

BETH BECKARD - WARREN COUNTY RECORDER
Doc #: 448369 Type: DEED
Filed: 12/11/2003 13:36:33 \$ 28.00
OR Volume: 3377 Page: 720 Return: M
Rec#: 33941 Pages: 2
CHICAGO TITLE INSURANCE CO

BOOK 3377 PAGE 721

2/2/07

Quit-Claim Deed

Rodney K. Litteral and Monica L.M. Litteral, Husband and Wife, of Dayton, Ohio for valuable consideration paid, grant(s) to First Property Group, Ltd., whose tax-mailing address is: P.O. Box 8228, Carlisle, OH 45005-8228, the following **REAL PROPERTY**:



See Legal Exhibit "A" attached hereto and made a part hereof.

Subject to all legal highways; building and zoning ordinances; easements, conditions and restrictions of record; and real estate taxes and assessments not yet due and payable.

Prior Instrument Reference: See attached

Executed this 7 November, 2007
day of ~~October~~, 2007.

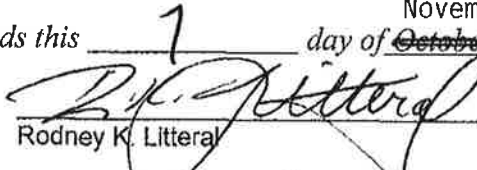
The undersigned has hereunto set their hands this 7 November, 2007
day of ~~October~~, 2007.

Rodney K. Litteral

Monica L.M. Litteral

State of Ohio, Montgomery County

ss.

BE IT REMEMBERED, That on this 7 November, 2007
day of ~~October~~, 2007, before me, the
subscriber, a Notary Public in and for said state, personally came Rodney K. Litteral and
Monica L.M. Litteral, the Grantors in the foregoing deed, and acknowledged the signing thereof
to be their voluntary act and deed.

IN TESTIMONY THEREOF, I have hereunto subscribed my name and affixed my
official seal on the day and year last aforesaid.

FELICIA McPHAIL, Notary Public
In and for the State of Ohio
My Commission Expires Dec. 20, 2011

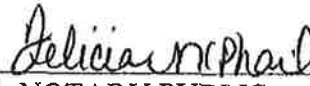
NOTARY PUBLIC

This instrument was prepared by Anne E. Ross, Attorney at Law, 300 W. Monument Avenue,
Dayton, OH 45402.

Auditor's and Recorder's Stamps

WARREN COUNTY



673199

BOOK 4579 PAGE 313

PAGE 1 OF 3

METROPOLITAN TITLE AGENCY, INC.

23-BZA-005 Exhibit 50A

LEGAL EXHIBIT "A"

1. 7866 Country Brook Court, Springboro, OH 45066
Parcel No. 05-31-205-0430 D2
Prior Instrument: Book 2277, Page 720
SITUATED IN SECTION 31, TOWN 3, RANGE 5 IN THE TOWNSHIP OF CLEARCREEK, COUNTY OF WARREN, STATE OF OHIO AND BEING LOT NUMBERED 43 ON THE REPLAT OF LOTS 21, 22 AND 23 COUNTRY BROOK, SECTION ONE AS RECORDED IN PLAT BOOK 63, PAGE 63 OF THE PLAT RECORDS OF WARREN COUNTY, OHIO.

2. 34 S. Harbine Avenue, Dayton, OH 45403
Parcel No. R72-047-05-0043
Prior Instrument: 98-0373 D04
SITUATE IN THE CITY OF DAYTON, COUNTY OF MONTGOMERY AND STATE OF OHIO AND BEING LOT NUMBER EIGHTEEN THOUSAND EIGHT HUNDRED SEVENTY (18870) OF THE CONSECUTIVE NUMBERS OF LOTS ON THE REVISED PLAT OF THE SAID CITY OF DAYTON, OHIO.

3. 349-51 Kenilworth Avenue, Dayton, OH 45405
Parcel No. R72-068-10-0067
Prior Instrument: 94-0439 C07
SITUATE IN THE STATE OF OHIO, COUNTY OF MONTGOMERY AND CITY OF DAYTON, AND BEING LOT NUMBERED THIRTY FOUR THOUSAND SIX HUNDRED EIGHTY ONE (34681) OF THE CONSECUTIVE NUMBERS OF LOTS ON THE REVISED PLAT OF THE SAID CITY OF DAYTON, OHIO.

4. 101-03 Marathon Avenue, Dayton, OH 45405
Parcel No. R72-071-09-0019
Prior Instrument: 94-0115 E09
SITUATE IN THE STATE OF OHIO, COUNTY OF MONTGOMERY AND CITY OF DAYTON, AND BEING LOT NUMBERED THIRTY TWO THOUSAND EIGHT HUNDRED EIGHTY ONE (32881) OF THE CONSECUTIVE NUMBERS OF LOTS ON THE REVISED PLAT OF THE SAID CITY OF DAYTON, OHIO.

5. 710-12 N. Keowee Street, Dayton, OH 45404
Parcel No. R72-056-08-0045
Prior Instrument: 93-0770 C09
SITUATED IN THE CITY OF DAYTON, COUNTY OF MONTGOMERY, AND STATE OF OHIO AND BEING LOT NUMBERED 18034 OF THE CONSECUTIVE NUMBERS OF LOTS ON THE REVISED PLAT OF THE SAID CITY OF DAYTON, OHIO.

BOOK 4579 PAGE 314

Rodney and Monica Litteral to First Property Group, Ltd.

6. 207 Pleasant Avenue, Dayton, OH 45403

Parcel No. R72-044-12-0019

Prior Instrument: 92-0479 A01

SITUATE IN THE CITY OF DAYTON, COUNTY OF MONTGOMERY, AND STATE OF OHIO AND BEING LOT NUMBERED THIRTY SEVEN THOUSAND SIX HUNDRED FORTY NINE (37649) OF THE CONSECUTIVE NUMBERS OF LOTS ON THE REVISED PLAT OF THE SAID CITY OF DAYTON, OHIO.

7. 352 Illinois Avenue, Dayton, OH 45410

Parcel No. R72-035-09-0014

Prior Instrument: 02-104043

SITUATED IN THE STATE OF OHIO, COUNTY OF MONTGOMERY, AND CITY OF DAYTON, AND BEING LOT NUMBERED FORTY THOUSAND ONE HUNDRED THIRTY THREE (40133) OF THE CONSECUTIVE NUMBERS OF LOTS ON THE REVISED PLAT OF THE SAID CITY OF DAYTON, OHIO.

8. 2028-30 Wayne Avenue, Dayton, OH 45410

Parcel No. R72-034-05-0022

Prior Instrument: 94-0416 E05

SITUATE IN THE COUNTY OF MONTGOMERY, STATE OF OHIO, AND IN THE CITY OF DAYTON, AND BEING MORE FULLY BOUNDED AND DESCRIBED AS FOLLOWS: LOT NUMBERED SEVENTEEN THOUSAND TWO HUNDRED FIFTY ONE (17,251) OF THE CONSECUTIVE NUMBERS OF THE REVISED LOTS OF THE SAID CITY OF DAYTON, OHIO.

BETH DECKARD - WARREN COUNTY RECORDER
Doc #: 673199 Type: DEED
Filed: 11/20/2007 14:25:39 \$ 36.00
OR Volume: 4579 Page: 313 Return: M
Rec#: 21433 Pages: 3
METROPOLITAN TITLE AGENCY

WARREN COUNTY

pd
TRANSFERRED
673199
st
NOV 20 2007
SEC. 319.02 COMPLIED WITH
NICK NELSON, Auditor
WARREN COUNTY, OHIO

PAGE 3 OF 3
BOOK 4579 PAGE 315

23-BZA-005 Exhibit 50C



DATE:	DOCUMENT ID	DESCRIPTION	FILING	EXPED	PENALTY	CERT	COPY
10/10/2007	200728301150	ARTICLES OF ORGANIZATION/DOM. LLC (LCA)	125.00	.00	.00	.00	.00

Receipt

This is not a bill. Please do not remit payment.

FIRST MANAGEMENT GROUP, LTD
 805 CENTRAL AVENUE
 CARLISLE, OH 45005

**STATE OF OHIO
 CERTIFICATE**

Ohio Secretary of State, Jennifer Brunner

1732270

It is hereby certified that the Secretary of State of Ohio has custody of the business records for

FIRST PROPERTY GROUP, LTD.

and, that said business records show the filing and recording of:

Document(s)
ARTICLES OF ORGANIZATION/DOM. LLC

Document No(s):
200728301150



United States of America
 State of Ohio
 Office of the Secretary of State

Witness my hand and the seal of
 the Secretary of State at Columbus,
 Ohio this 10th day of October, A.D.
 2007.

Ohio Secretary of State



Prescribed by :

The Ohio Secretary of State
Central Ohio: (614) 466-3910
Toll Free: 1-877-SOS-FILE (1-877-767-3453)

www.sos.state.oh.us
e-mail: busserv@sos.state.oh.us

Expedite this Form: (Select One)	
Mail Form to one of the Following:	
<input type="radio"/> Yes	PO Box 1390 Columbus, OH 43216 *** Requires an additional fee of \$100 ***
<input checked="" type="radio"/> No	PO Box 670 Columbus, OH 43216

**ORGANIZATION / REGISTRATION OF
LIMITED LIABILITY COMPANY**
(Domestic or Foreign)
Filing Fee \$125.00

THE UNDERSIGNED DESIRING TO FILE A:

(CHECK ONLY ONE (1) BOX)

<input checked="" type="checkbox"/> (1) Articles of Organization for Domestic Limited Liability Company (115-LCA) ORC 1705	<input type="checkbox"/> (2) Application for Registration of Foreign Limited Liability Company (108-LFA) ORC 1705
(Date of Formation)	(State)

Complete the general information in this section for the box checked above.

Name First Property Group, Ltd.

Check here if additional provisions are attached

* If box (1) is checked, name must include one of the following endings: limited liability company, limited, Ltd, L.t.d., LLC, L.L.C.

Complete the information in this section if box (1) is checked.

Effective Date (Optional) _____ Date specified can be no more than 90 days after date of filing. If a date is specified,
(mm/dd/yyyy) the date must be a date on or after the date of filing.

This limited liability company shall exist for _____
(Optional) (Period of existence)

Purpose (Optional) To engage in any lawful business by the Ohio Revised Code or the laws of any jurisdiction
in which this limited liability company may do business. This limited liability company shall
have the authority to do all things necessary or convenient to operate its business.

The address to which interested persons may direct requests for copies of any operating agreement and any bylaws
of this limited liability company is

(Optional)

(Name)

(Street) NOTE: P.O. Box Addresses are NOT acceptable.

(City) _____ (State) _____ (Zip Code)

Complete the information in this section if box (1) is checked Cont.

ORIGINAL APPOINTMENT OF AGENT

The undersigned authorized member, manager or representative of

First Property Group, Ltd.

(name of limited liability company)

hereby appoint the following to be statutory agent upon whom any process, notice or demand required or permitted by statute to be served upon the limited liability company may be served. The name and address of the agent is:

Rodney Litteral

(Name of Agent)

805 W Central Ave.

(Street)

NOTE: P.O. Box Addresses are NOT acceptable.

Carlisle

(City)

Ohio

(State)

45005

(Zip Code)

Must be authenticated by an authorized representative

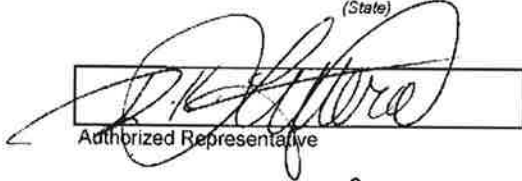

Authorized Representative

October 8, 2007

Date

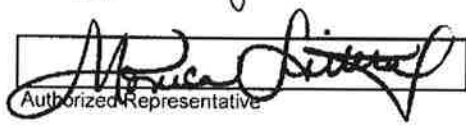

Authorized Representative

October 8, 2007

Date

ACCEPTANCE OF APPOINTMENT

The undersigned, named herein as the statutory agent for

First Property Group, Ltd.

(name of limited liability company)

hereby acknowledges and accepts the appointment of agent for said limited liability Company.



(Agent's signature)

PLEASE SIGN PAGE (3) AND SUBMIT COMPLETED DOCUMENT

Complete the information in this section if box (2) is checked.

The address to which interested persons may direct requests for copies of any operating agreement and any bylaws of this limited liability company is

(Name)

(Street)

NOTE: P.O. Box Addresses are NOT acceptable.

(City)

(State)

(Zip Code)

The name under which the foreign limited liability company desires to transact business in Ohio is

The limited liability company hereby appoints the following as its agent upon whom process against the limited liability company may be served in the state of Ohio. The name and complete address of the agent is

(Name)

(Street)

NOTE: P.O. Box Addresses are NOT acceptable.

(City)

Ohio

(State)

(Zip Code)

The limited liability company irrevocably consents to service of process on the agent listed above as long as the authority of the agent continues, and to service of process upon the OHIO SECRETARY OF STATE if:

- a. the agent cannot be found, or
- b. the limited liability company fails to designate another agent when required to do so, or
- c. the limited liability company's registration to do business in Ohio expires or is cancelled.

REQUIRED
Must be authenticated (signed)
by an authorized representative
(See Instructions)

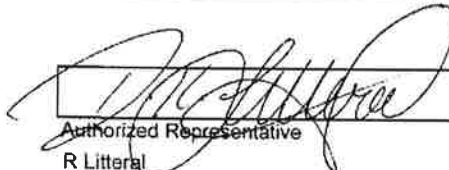

Authorized Representative

R Litteral

(Print Name)
805 W Central Ave.

Carlisle OH 45005-8228

October 8, 2007

Date



Authorized Representative

M Litteral

(Print Name)
805 W Central Ave.

Carlisle OH 45005-8228

October 8, 2007

Date

23-BZA-005 Exhibit 51D